



YARD FORCE®

LAWN & GARDEN EQUIPMENT

Model: EW U15

PRESSURE WASHER

Instruction Manual



WARNING!

Protect yourself and others by observing all safety information, warnings and cautions. Failure to comply with instructions could result in personal injury and/or damage to product or property.



Please retain instructions for future reference!

Hotline: 1300 418 640

Monday/Friday: 9.00am to 4.30pm

Saturday: 9.00am to 3.00pm

Email: service@actionspares.com.au



Read this manual carefully prior to assembling and operating the pressure washer. It is dangerous to operate this product without being familiar with these instructions. Keep this manual in a safe place and have it ready for future reference.

Fig. 1

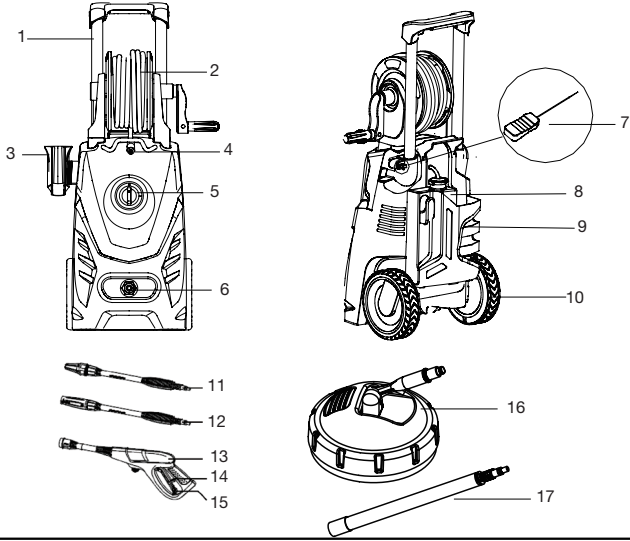

Fig. 2

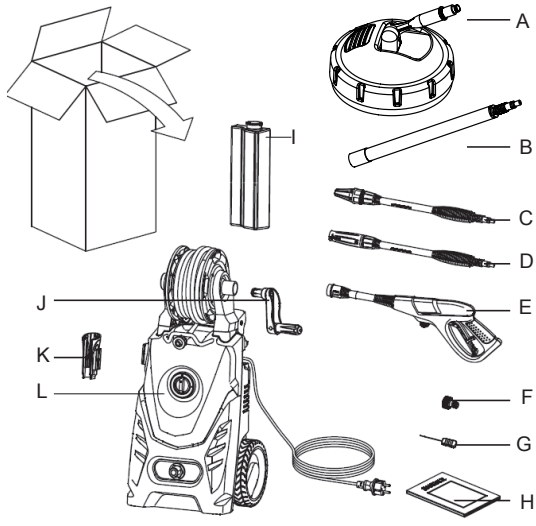

Fig. 3

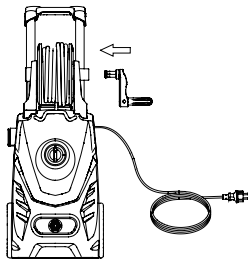

Fig. 4

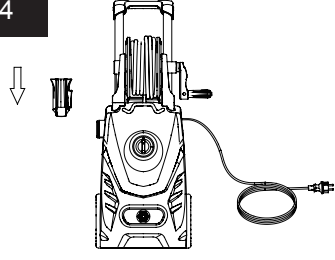

Fig. 5

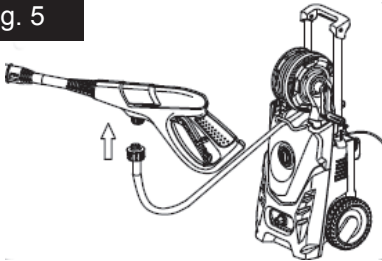

Fig. 6

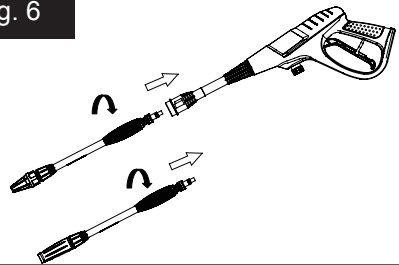

Fig. 7

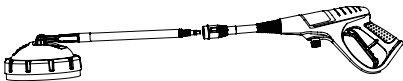

Fig. 8

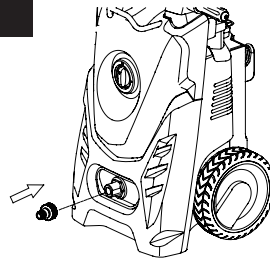

Fig. 9

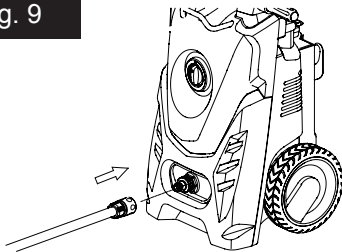

Fig. 10

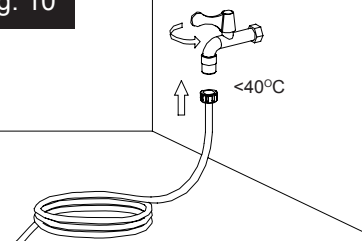

Fig. 11

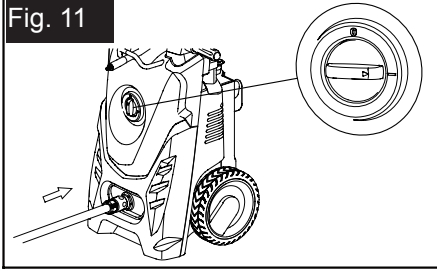

Fig. 12

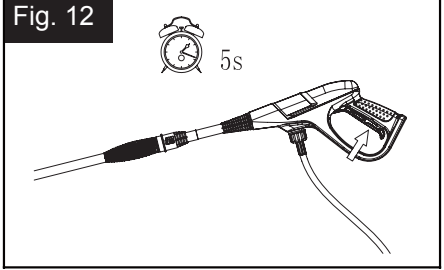

Fig. 13

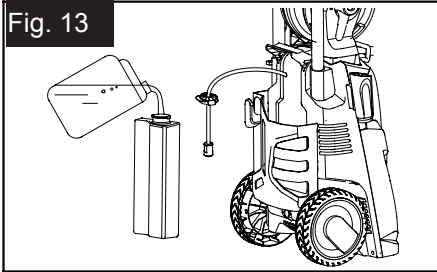

Fig. 14

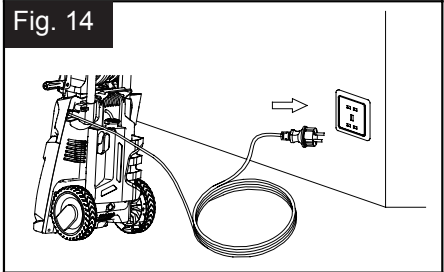

Fig. 15

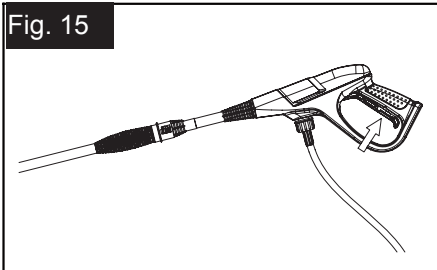

Fig. 16

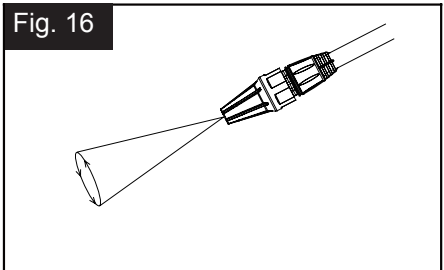

Fig. 17

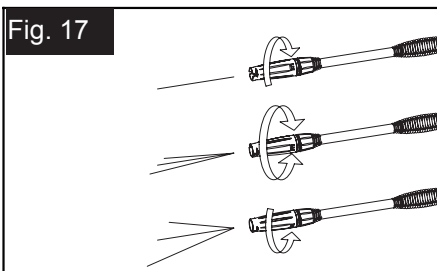

Fig. 18

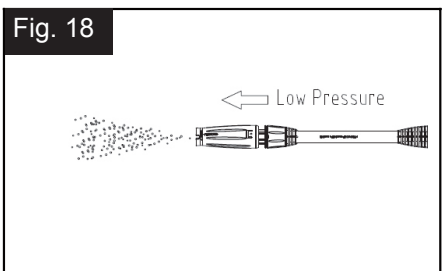

Fig. 19

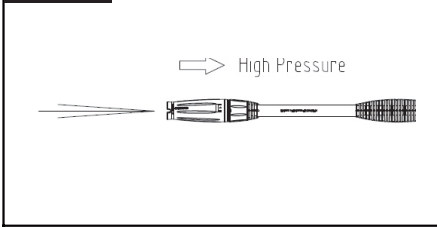

Fig. 20

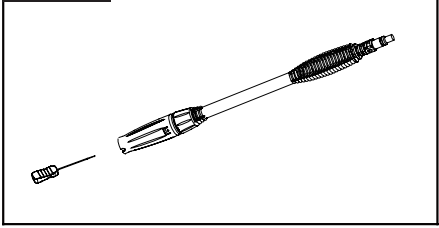
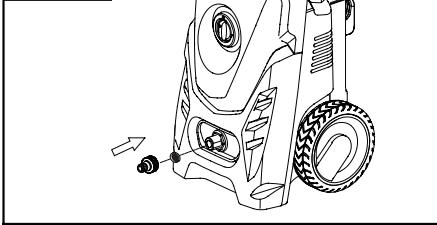

Fig. 21



YARD FORCE

EW U15 Instruction Manual

CONTENTS

Intended use	8
Parts description	8
Package contents	9
Symbols	10
Safety warnings	12
Assembly and preparation	17
Operation	18
Cleaning, maintenance & storage	21
Troubleshooting	22
Technical data	23
Warranty	24



WARNING: Read instruction manual carefully before using this pressure washer. Failure to follow the instructions may result in severe injury or damage to the pressure washer. Keep the instruction manual for future use. If you give the pressure washer to others, please ensure that the instruction manual is included.



WARNING: This appliance is not intended for use by persons (including children) with reduced physical, sensory or mental capabilities, or lack of experience and knowledge, unless they have been given supervision or instruction concerning use of the appliance by a person responsible for their safety. Children should be supervised to ensure that they do not play with the appliance.

INTENDED USE

The pressure washer is designed only for cleaning façades, patios, walkways, garden tools, vehicles, etc. It is only intended for private use and is not suitable for commercial use. Use the pressure washer only as described in this user manual. Any other use is deemed improper and may result in damage to property or even personal injury. The pressure washer is not a children's toy. The manufacturer or vendor accepts no liability for damage caused by improper or incorrect use.

PARTS DESCRIPTION

Parts description (Fig. 1)

1. Main handle.
2. Hose wheel.
3. Gun holder.
4. High pressure outlet spigot.
5. ON/OFF switch.
6. Water inlet spigot.
7. Nozzle pin.
8. Detergent tank.
9. Accessory storage
10. Wheel.
11. Turbo lance.
12. Adjustable lance.
13. Spray gun.
14. Trigger lock.
15. Gun trigger
16. Patio cleaner.
17. Extension Lance

PACKAGE CONTENTS

Parts description (Fig. 2)

- A. 1 x Patio cleaner.
- B. 1 x Extension lance
- C. 1 x Turbo lance.
- D. 1 x Adjustable lance.
- E. 1 x Spray gun.
- F. 1 x Water inlet adapter.
- G. 1 x Nozzle cleaning pin.
- H. 1 x Instruction manual.
- I. 1 x Detergent bottle.
- J. 1 x Hose wheel handle.
- K. 1 x Gun holder.
- L. 1 x Pressure washer.

- Remove all packing material.
- Check the completeness of the package content.
- Check the pressure washer and its accessories for transportation damages.



WARNING: Danger of suffocating! Packing materials are not toys!
Children must not play with plastic bags!



WARNING: If any parts are damaged or missing, do not operate this pressure washer until the missing parts are replaced.



If any parts are missing or damaged, please contact Action Spares 1300 777 137.



Recycle/dispose of packaging materials in accordance to the regulations and requirements of your local council.

SYMBOLS

Symbols are used in this manual and/or on the product to attract your attention to possible risks. These symbols and the explanations that accompany them must be understood.



WARNING! OR CAUTION!



READ the user manual before using the pressure washer.



Disconnect the mains plug immediately if the mains cable is damaged, has been badly twisted or is completely cut through and when the pressure washer is left unattended.



WARNING! Never direct the discharge stream at persons, animals, the pressure washer itself or electric components.



WARNING! Always wear ear and eye protection.



WARNING! Always wear protective footwear.

SYMBOLS



Do not connect to potable water without the use of a check valve.



Rated sound power level.



Double insulation, Class II pressure washer.



Australian Regulatory Compliance Mark.

SAFETY WARNINGS



WARNING: Read all safety warnings and all instructions. Failure to follow the warnings and instructions may result in electric shock, fire and/or serious injury.

1. This pressure washer is not intended for use by persons (including children) with reduced physical, sensory or mental capabilities, lack of experience and knowledge.
2. The electric supply connection shall be made by a qualified electrician and comply with AS 3000.
3. For additional electrical protection. *It is recommended that this pressure washer be used in conjunction with a residual current device (RCD) with a rated residual current of 30mA or less.*
4. High pressure jets can be dangerous if subject to misuse. *The jet must not be directed at persons, live electrical equipment or the pressure washer itself.*
5. Keep operating area clear of all persons. *Do not use the pressure washer within range of persons.*
6. Do not direct the jet against yourself or others in order to clean clothes or footwear.
7. Risk of explosion. *Do not spray flammable liquids.*
8. High pressure cleaners shall not be used by children or untrained personnel.
9. High pressure hoses, fittings and couplings are important for the safety of the pressure washer. *Use only hoses, fittings and couplings recommended by the manufacturer.*

SAFETY WARNINGS

10. To ensure pressure washer safety, use only original spare parts from the manufacturer or approved by the manufacturer.
11. The pressure washer shall be disconnected from its power source during cleaning or maintenance and when replacing parts or converting the pressure washer to another function. *For mains operated pressure washers, by removing the mains plug from the socket outlet.*
12. Do not use the pressure washer if a supply cord or important parts of the pressure washer are damaged, e.g. *safety devices, high pressure hoses, gun trigger.*
13. Inadequate extension cords can be dangerous. *If an extension cord is used, it shall be suitable for outdoor use, and the connection has to be kept dry and off the ground. It is recommended that this is accomplished by means of a cord reel which keeps the socket at least 60 mm above the ground.*
14. Always switch off the mains disconnecting switch when leaving the pressure washer unattended.
15. To reduce the risk of injury, close supervision is necessary when a pressure washer is used near children.
16. Know how to stop the pressure washer and bleed pressure quickly, be thoroughly familiar with the controls.
17. Stay alert! *Watch what you are doing.*
18. Do not operate the pressure washer when fatigued or under the influence of alcohol or drugs.

SAFETY WARNINGS

19. Do not overreach or stand on unstable support. *Keep good footing and balance at all times.*
20. Follow the maintenance instructions specified in the instruction manual.
21. Always wear protective clothing and safety glasses. *Loose particles and other debris are propelled at high speed by the water jet.*
22. Always wear ear protection.
23. Never use the pressure washer in bare feet or open toe shoes. *Always wear protective footwear.*
24. When connecting the water inlet to the water supply mains, local regulations must be observed. *In some areas, the pressure washer must not be connected directly to drinking water supply without a back flow preventers. Water that has flowed through back flow preventers is considered to be non-potable.*
25. Children should be supervised to ensure that they do not play with the pressure washer.
26. If the supply cord is damaged, it must be replaced by the manufacturer or its service agent or a similarly qualified person in order to avoid a hazard.
27. Always ensure that a pressure washer is switched off when not in use to avoid unintentionally starting.
28. Do not retrofit or make any unauthorised changes to the pressure washer, or use unapproved parts.
29. Use only hoses, fittings and couplings supplied and recommended by the manufacturer.
30. Never carry the pressure washer by the cable or hoses.

SAFETY WARNINGS

31. Do not carry the pressure washer with your finger on the ON/OFF switch when it is connected to the mains.
32. Remove the main plug from the plug socket if you are not using the pressure washer, when transporting it or when it is left unattended, when checking the pressure washer, cleaning it or removing blockages, when undertaking cleaning or maintenance work or changing accessories, if the power or extension cable is damaged, after contact with foreign bodies, or in the event of abnormal vibration.
33. Do not attempt to repair the pressure washer yourself. *All work not indicated in these instructions is to be carried out only by service stations authorised by the manufacturer.*
34. Do not use the pressure washer near flammable liquids or gases. *There is a risk of fire or explosion.*
35. Do not use the pressure washer if a supply cord, safety devices, hoses, switch or the gun trigger is damaged.
36. If an extension cord is used, the plug and socket must be of watertight construction. *Inadequate extension cords can be dangerous.*
37. The operator or user is responsible for accidents or damages to other people or their property.
38. Store the pressure washer in a dry location and out of the reach of children.
39. Handle the pressure washer with care. *Keep the pressure washer clean for safer and more efficient working.*

SAFETY WARNINGS

40. Ensure that the mains voltage matches the information of the label.
41. Before each use, check the pressure washer, power cable and plug for damage.
42. Damaged cables, coupling and plugs or connecting leads not to be used. *Remove the mains plug from the plug socket immediately if the mains cable is damaged or cut.*
43. Do not use the pressure washer if the switching action of the ON/OFF switch is impaired. *Have the damaged switch replaced by a service centre.*
44. Do not use the pressure washer for purposes other than those specified.
45. Use only detergents designed for use in pressure washers.
46. Do not use the pressure washer in the horizontal position.

ASSEMBLY AND PREPARATION



WARNING: Unplug the power cord before assembly.

NOTE: A Phillips type screw driver will be required for assembly of the pressure washer.

Follow these steps in conjunction with Fig. 1 & 2.

1. Insert the hose wheel handle (J) into the installation hole at the side of the hose wheel and press in firmly until the handle lock into position. Fig. 3.
2. Insert the gun holder (K) into the slots in the side of the main body of the pressure washer (L) and press down firmly until the brackets lock into position. Fig. 4.
3. Place a small amount of grease or vasoline on the thread of the spray gun (E).
4. Screw the high pressure outlet hose (Fig. 5) to the spray gun (E) and secure. Fig. 5.
5. To use the lance, push the lance (C) or (D) into the spray gun (Fig. 13) and twist it to lock into the position. Fig. 6.
6. To use the patio cleaner, push the patio cleaner (A) into the extension lance (B) and twist it to lock into the position. Then push the extension lance (B) into the spray gun (Fig. 13) and twist it to lock into the position. Fig. 7.
7. Screw the water inlet adapter (F) to the pressure washer. Fig. 8.
8. Attach your garden hose (not supplied) to the water inlet adaptor (F). Fig. 9.
Connect your garden hose to a COLD water tap and turn the water supply ON. Fig. 10.
Note: If the tap is not open sufficiently or your mains water flow is too low then the pressure washer will not work correctly.



CAUTION! Only connect the pressure washer to COLD water. Hot water will damage the pressure washer.

9. Check that the ON/OFF switch is in the OFF position.

OPERATION



WARNING! Before switching on the pressure washer, make sure that the pressure washer is completely assembled and all the hoses are properly connected.



WARNING! Make sure the pressure washer stands on flat ground in a secure and stable position.



WARNING! Hold the spray gun and the lance with both hands when using. Be aware of the recoil.



WARNING! Always wear hearing protection, safety glasses and protective footwear when operating the pressure washer.



WARNING! To prevent an accidental spraying operation, keep the trigger lock engaged when not actually spraying, moving the pressure washer or adjusting the lance.



CAUTION! Never operate the pressure washer without water as dry running may damage the pump. Use a water filter if the water is contaminated.

NOTE: Before switching ON the pressure washer, prime the pump and high pressure hose first by squeezing the gun trigger for around 5 seconds with the water supply turned on.

PRIMING (FIG. 12)

- Check that the water supply is turned on.
- Squeeze the gun trigger for 5 seconds or until water squirts from the end of the lance. This is required to prime the pressure washers pump and the high pressure hose before starting the pressure washer.

DETERGENT (FIG. 13)



CAUTION! Use only detergents designed for use in pressure washers only.

If you would like to use detergent for the job at hand.

- Remove detergent bottle from the rear of the pressure washer.
- Fill detergent bottle with a good quality pressure washer detergent.

NOTE: Detergent can only be dispensed with the adjustable lance that is set to low pressure mode. See LANCE OPERATION

OPERATION

STARTING THE PRESSURE WASHER (FIG. 14 & 15)

- Check that the water supply is turned on.
- Check that the pressure washer and high pressure hose have been primed.
- Engage the trigger lock on the spray gun to stop accidental operation.
- Plug the pressure washer into the mains power outlet.
- Set the ON/OFF switch to the ON position.

The pressure washer's motor will now run until the unit reaches maximum pressure. The motor will then stop. When the gun trigger on the spray gun is depressed, water will spray from the lance and the motor will restart.

- To start spraying release the trigger lock and then squeeze gun trigger.
- To stop spraying release the gun trigger.
- Engage the trigger lock on the spray gun to stop accidental operation.

THE TURBO LANCE (FIG. 16)

A turbo lance, sometimes referred to as a rotary lance, is a very effective tool that can significantly reduce cleaning time.

The turbo nozzle combines the power of a narrow stream and the efficiency of 25 degree fan pattern. This swirls the stream into a cone shape that cleans a larger area.

CAUTION! Since a turbo lance uses a narrow stream, only use it in applications where the cleaning surface cannot be damaged by a narrow high impact spray. Always test on an inconspicuous area first to ensure you do not damage the surface.



WARNING! Do not adjust the adjustable lance while spraying. Engage the trigger lock on the spray gun to stop accidental operation.

THE ADJUSTABLE LANCE (FIG. 17)

Pencil or fan water spray patterns can be achieved by turning the tip of the lance clockwise or anti-clockwise. The fan spray pattern is the most commonly used for general cleaning operations. The pencil spray pattern is used to remove localized stubborn contamination such as oil stains.

HOW TO USE DETERGENT (FIG. 18 & 19)

The adjustable lance has an additional function to allow the use of the detergent from the detergent bottle.

- If the end of the lance is pulled out to the low pressure position, the contents of the detergent bottle will automatically be dispensed with the low pressure stream.
- To stop the detergent flow, return the lance to the high pressure mode.

OPERATION

NOTE: The pressure washer cannot dispense detergent in high pressure mode.



CAUTION! Before using the pressure washer to clean patio paving slabs it is advisable to test a small area first, the use of a pressure washer could damage the surface.

AFTER USE

- Set the ON/OFF switch to OFF position.
- Turn off the water supply.
- Disengage the trigger lock.
- Squeeze the gun trigger and discharge the residual pressure inside the hoses.
- Engage the trigger lock.
- Disconnect you garden hose.

NOTE: If the residual pressure in the lance and pressure hose are not fully released, the high pressure hose will NOT be able to be unscrewed from the main unit or the spray gun.

CLEANING, MAINTENANCE & STORAGE



WARNING! Before cleaning, maintenance or storing, make sure that the pressure washer ON/OFF switch is in the OFF position, the power plug is removed from the electrical supply, the water supply has been turned off, the water supply hose is disconnected and any residual pressure in the lance and high pressure hose has been released.

CLEANING

- Wipe the pressure washer with a slightly damp cloth. Do not clean the pressure washer using a high pressure water jet.

MAINTENANCE

There are NO user maintainable parts inside the pressure washer. If the main unit requires service it should only be repaired by an authorised service centre.

- Clean the adjustable lance with the nozzle cleaning pin provided as required. (Fig. 19)
- Clean the water filter.

The pressure washer is equipped with a small water filter inside of the water inlet adaptor to protect the pump from debris in the water supply. If the filter is not kept clean, then the water flow to the machine will be restricted and may damage the pressure washer. (Fig. 20)

Note: The filter should be checked before each use.

- Remove water inlet adaptor to get access to the filter.
- Remove the filter
- Rinse filter until it is free of debris and blockage.
- Replace the filter and inlet adapter.

STORAGE

- Disassemble the lance and spray gun.
- Remove the hoses from the pressure washer.
- Drain any residual water from the high pressure hose, lance, spray gun and pressure washer.
- Wipe all components down with a soft dry cloth.
- Store the pressure washer in a dry well ventilated area out of the reach of children.

TROUBLESHOOTING



WARNING! Faults that cannot be rectified with the help of the following table must be referred to an authorised service centre.

Problem	Possible cause	Possible solution
Pressure washer not running.	No Power.	Check power outlet is turned ON.
	Residual pressure in high pressure hose.	Press the gun trigger on spray gun.
	ON/OFF switch set to "0" OFF.	Set the ON/OFF switch to "I" ON position.
	Motor protection has activated.	Allow to cool for 15 minutes.
Output pressure is steady but too low.	High pressure hose is damaged.	Change the high pressure hose.
	Leaks in the high pressure connections.	Hand tighten high pressure screw connections.
Leaks in the machine.	Internal leaks.	Consult authorised service centre.
	Hose connections loose.	Hand-tighten the water intake adapter and the high pressure hose screw connections.
Irregular operating pressure.	Air in the inlet water hose.	Check the supply hose and hose connection, replace if necessary.
	The water filter is clogged.	Clean the water filter.
	Water supply hoses kinked.	Straighten water supply hoses.
	Inadequate water supply.	Check the water supply flow.
The high pressure washer operates intermittently.	Power cable is damaged.	Consult authorised service centre.
	Internal loose electrical connection.	Consult authorised service centre.
	ON/OFF switch is defective.	Consult authorised service centre.
The motor starts but there is no build up of pressure.	The water filter is clogged.	Clean the water filter.
	No Water.	Check that the water supply is turned on and that there is no air in the supply hose.

TECHNICAL DATA

Model No.	EW U15
Rated input voltage	230-240V~, 50 Hz
Rated input power	2000 W
Rated pressure	1600 PSI / 11 MPa
Max. pressure	2200 PSI / 15.2 MPa
Max inlet pressure	87 PSI / 6 Bar
Rated Flow rate	5.5 L/min
Max. flow rate	7.3 L/min
High pressure hose length	6.5 m
Cable Length	5 m
Pump type	Aluminium
Weight	14.5 Kg

WARRANTY

WARRANTY

This product is covered by a 1 year parts and labour warrant against manufacturing defects.

Our goods come with guarantees that cannot be excluded under the Australian Consumer Law.

You are entitled to a replacement or refund for a major failure and for compensation for any other reasonably foreseeable loss or damage. You are also entitled to have the goods repaired or replaced if the goods fail to be of acceptable quality and the failure does not amount to a major failure.

This warranty will not apply:

- (i) where this product has been subjected to misuse, abuse, accident or want of care;
- (ii) where this product has been used for a purpose for which it was not designed or is not suited;
- (iii) where the service of this product has been undertaken by a non-authorized person or company or if non-approved parts have been used;
- (iv) where this product has been used for trade, industrial or commercial purposes .

Should service become necessary during the warranty period, the purchaser should contact Action Spares on 1300 418 640.

In order to obtain warranty service, the purchaser must present the store receipt showing the name of the retailer and the date of purchase.

The period of the warranty begins from the original date of purchase, notwithstanding any subsequent repair or parts replacement.

Purchaser shall be responsible for all transport charges to and from the Authorised Service Centre.

Damage in transit is not covered by this warranty. The purchaser should remove from the product any liquids (if applicable) before sending the product for service or repair.

The product should be packed securely to prevent damage.

WARRANTY EXCLUSIONS

Wear parts or service related parts required when performing normal and regular maintenance of this product are not covered by warranty unless it is found to be defective by an Authorised Service Centre.

These include, but are not limited to: Filters, "O" rings, washers.